



Bid Specifications

Bid Item #25-244

Cell Light Installation for Charles B. Webster Detention Center (CBWDC)

For

Augusta, Georgia – Sheriff's Office

Bid Due: Friday, October 31, 2025 @ 11:00 a.m.

LOCAL VENDOR PREFERENCE IS APPLICABLE

Until further notice

**All bid openings, conferences, and evaluation meetings
will be conducted by electronic teleconferencing via TEAMS.
Instructions are enclosed.**

Sec. 1-10-50. Sealed bids selection method:

Bid acceptance and bid evaluation. Provided that the bids are delivered to the Procurement Director at the time, place, and under the conditions contained in the Invitation for Bids, the bids shall be conditionally accepted without alteration or correction pending evaluation.

To Ensure Timely Deliveries; It Is The Responsibility Of The Vendor To Ensure Their Bid Submittal Is Received By The Time Specified Above. All Submittals MUST Be Received During Our Normal Office Hours From 8:30 A.M. To 5:00 P.M., Monday Through Friday.

Thanks for doing business with us . . .

*Andy Penick, Procurement Director
535 Telfair Street, Room 605
Augusta, Georgia 30901*



Table of Contents

Invitation to Bid

Electronic TEAMS Information

Instructions to Submit

- Purpose
- Viewing of the Augusta Code
- Compliance with Laws
- Bid for All or Part
- All protests shall be made in writing
- Local Vendor Preference
- Minority/Women Business Enterprise (MWBE) Policy
- Augusta Georgia License Requirement
- Terms of Contract

Notice to All Vendors

(Required to be returned with your submittal. Both documents must be notarized)

Attachment B - **Return the 2 pages**

Systematic Alien Verification for Entitlements (SAVE) Program - **Return the 1 page**

Trade Secret Status Affidavit

Exception Sheet

Local Vendor Registration Form

Minority and Women Owned Business Enterprise Program Ordinance Requirements

Bid Specifications

LSBP Program Preference

No Response Letter

Revised 9/6/24

Invitation to Bid

Sealed bids will be received at this office until **Friday, October 31, 2025 @ 11:00 a.m.** via TEAMS Meeting ID: 222 976 220 355; Passcode: 25242 for furnishing:

Bid Item #25-244 **Cell Light Installation for Charles B. Webster Detention Center (CBWDC) for Augusta, GA – Sheriff's Office**

Bids will be received by Augusta, GA Commission hereinafter referred to as the OWNER at the offices of:

Andy Penick, Procurement Director
Augusta, GA. Procurement Department
535 Telfair Street - Room 605
Augusta, Georgia 30901

Bid documents may be obtained through the Augusta, Georgia web site under the Procurement Department **ARCbid, Euna OpenBids, and Georgia Procurement Registry**. Bid documents may also be obtained at the offices of Augusta, GA Procurement Department, 535 Telfair Street – Suite 605, Augusta, GA 30901 **(706-821-2422)**.

For an optional site visit, please contact Chester Huffman in advance at **(706) 821-1442** or via email at cvhuffman@augustaga.gov.

All questions must be submitted in writing by email to procbidandcontract@augustaga.gov to the office of the Procurement Department by **Friday, October 17, 2025 @ 5:00 P.M.** No bid will be accepted by email; all bids must be received by mail or hand delivered. **No deliveries will be accepted prior to 8:30 a.m. or after 5:00 p.m., as the building is closed to the public and delivery services outside of these hours.**

No bids may be withdrawn for a period of ninety (90) days after bids have been opened, pending the execution of contract with the successful bidder.

Invitation for bids and specifications. An invitation for bids shall be issued by the Procurement Office and shall include specifications prepared in accordance with Article 4 (Product Specifications), and all contractual terms and conditions applicable to the procurement. **All specific requirements contained in the invitation to bid including, but not limited to, the number of copies needed, the timing of the submission, the required financial data, and any other requirements designated by the Procurement Department are considered material conditions of the bid which are not waiveable or modifiable by the Procurement Director.** All requests to waive or modify any such material condition shall be submitted through the Procurement Director to the appropriate committee of the Augusta, Georgia Commission for approval by the Augusta, Georgia Commission. Please mark BID number on the outside of the envelope.

The local bidder preference program is applicable to this project. To be approved as a local bidder and receive bid preference an eligible bidder must submit a completed and signed written application to become a local bidder at least thirty (30) days prior to the date bids are received on an eligible local project. An eligible bidder who fails to submit an application for approval as a local bidder at least thirty (30) days prior to the date bids are received on an eligible local project, and who otherwise meets the requirements for approval as a local bidder, will not be qualified for a bid preference on such eligible local project.

GEORGIA E-Verify and Public Contracts: The Georgia E-Verify law requires contractors and all sub-contractors on Georgia public contract (contracts with a government agency) for the physical performance of services over \$2,499 in value to enroll in E-Verify, regardless of the number of employees. They may be exempt from this requirement if they have no employees and do not plan to hire employees for the purpose of completing any part of the public contract. Certain professions are also exempt. All requests for proposals issued by a city must include the contractor affidavit as part of the requirement for their bid to be considered.

Bidders are cautioned that acquisition of BID documents through any source other than the office of the Procurement Department is not advisable. Acquisition of BID documents from unauthorized sources placed the bidder at the risk of receiving incomplete or inaccurate information upon which to base his qualifications.

Correspondence must be submitted via mail or email as follows:

Augusta Procurement Department
Attn: Andy Penick, Procurement Director
535 Telfair Street, Room 605
Augusta, GA 30901
Email: procbidandcontract@augustaga.gov

No bid will be accepted by email; all bids must be received by mail or hand delivered.

Andy Penick, Procurement Director

Publish:

Augusta Chronicle September 25, 2025 and October 2, 9, 16, 2025
Metro Courier September 25, 2025

cc: Tameka Allen Administrator
 Major Chester Huffman Sheriff's Office

**PROCUREMENT DEPARTMENT BIDS AND CONTRACTS
ELECTRONIC BID OPENING INFORMATION**

The Augusta, Georgia Procurement Department conducts Public Bid Openings to award quality contracts for Augusta. Bidders may participate in our Public Bid Openings via webcast or teleconference by following the instructions outlined below:

[ELECTRONIC BID INSTRUCTIONS](#)

Join from a PC, Mac, iPad, iPhone, or Android device

***Bid Opening – Bid Item #25-244 Cell Light Installation
for Charles B. Webster Detention Center (CBWDC)
for Augusta, GA – Sheriff’s Office
Friday, October 31, 2025 @ 11:00 a.m.***

TEAMS Bid Opening:

1. Or go to <https://teams.microsoft.com> and enter meeting ID: **Meeting ID: 222 976 220 355**
2. Password: **25242**

For Assistance: Please Contact the Bid and Contract Team at (706) 821-2422

Revised 9/22/2025

INSTRUCTIONS TO SUBMIT

- 1.1 **Purpose:** The purpose of this document is to provide general and specific information for use by vendors in submitting a bid to supply Augusta, Georgia with equipment, supplies, and or services as listed above. All bids are governed by the Augusta, Georgia Code.
- 1.2 **Viewing the Augusta Code:** All bids are governed and awarded in accordance with the applicable federal and state regulations and the Augusta, Georgia Code. To view the Code visit Augusta’s website at www.augustaga.gov or <http://www.augustaga.gov/index.aspx?NID=685> **Guidelines & Procedures.**
- 1.3 **Compliance with laws:** The Bidder shall obtain and maintain all licenses, permits, liability insurance, workman's compensation insurance and comply with any and all other standards or regulations required by federal, state or Augusta, Georgia statute, ordinances, and rules during the performance of any contract between the Bidder and Augusta, Georgia. Any such requirement specifically set forth in any contract document between the Bidder and Augusta, Georgia shall be supplementary to this section and not in substitution thereof.
- 1.4 **Bids for All or Part:** Unless otherwise specified by Augusta, Georgia or by the Bidder, **AUGUSTA, GEORGIA RESERVES THE RIGHT TO MAKE AWARD ON ALL ITEMS, OR ON ANY OF THE ITEMS ACCORDING TO THE BEST INTEREST OF AUGUSTA, GEORGIA.** Bidder may restrict his bid to consideration in the aggregate by so stating but must name a unit price on each item submitted upon.
- 1.5 **All protest shall be made in writing to:**

Attn: Andy Penick
Procurement Director
535 Telfair Street, Room 605
Augusta, GA 30901
Email:procbidandcontract@augustaga.gov
- 1.6 **Local Vendor Preference:** The Local Vendor Preference policy shall only be applied to projects of one-hundred thousand dollars (\$100,000) or less and only when the lowest local qualified bidder is within 10% or \$10,000, whichever is less of the lowest non-local bidders.
- 1.7 **Minority/Women Business Enterprise (MWBE) Policy:** *Court Order Enjoining Race-Based Portion of DBE Program Augusta, Georgia does not have a race or gender conscious Disadvantaged Business Enterprises (DBE) program for projects having Augusta, Georgia as the source of funding. Augusta does enforce mandatory DBE requirements of federal and state agencies on contracts funded by such agencies and has a DBE Program to comply with U.S. Department of Transportation (DOT), Federal Transit Administration (FTA), Federal Aviation Administration (FAA) and other federal and state mandated DBE requirements for certain DOT, FTA, FAA, and other federal and state assisted contracts as required by 49 C.F.R. Part 26, et. seq. and/or 49 C.F.R. Part 23, et. seq. This DBE program is only for DOT, FTA and FAA assisted contracts and other federal or state funded contracts having mandatory DBE requirements. (See Article 13 of the Augusta, GA. Code.)*

Augusta, Georgia prohibits any language in any solicitation, bid or contract that is inconsistent with the July 21, 2011, Court Order in the case, Thompson Wrecking, Inc. v. Augusta Georgia, civil action No. 1:07-CV-019. Any such language appearing in any Augusta, Georgia solicitation, bid or contract is void and unenforceable.

A copy of this Order can be reviewed at www.augustaga.gov home page.
- 1.8 **Augusta, Georgia License Requirement:** For further information contact the License and Inspection Department @ 706 312-5050.

General Contractors License Number: If applicable, in accordance with O.C.G.A. §43-41, or be subjected to penalties as may be required by law.

Utility Contractor License Number: If applicable, in accordance with O.C.G.A. §43-14, or be subjected to penalties as may be required by law.
- 1.9 **Terms of Contract:** (Check where applicable)
[] (A) Annual Contract
[] (B) One time Purchase.
[X] (C) Other



NOTICE TO ALL VENDORS

ADHERE TO THE BELOW INSTRUCTIONS AND DO NOT SUBSTITUTE FORMS

PLEASE READ CAREFULLY:

Attachment B is a consolidated document consisting of:

1. Business License Number Requirement (must be provided)
2. Acknowledgement of Addenda (must be acknowledged, if any)
3. Statement of Non-Discrimination
4. Non-Collusion Affidavit of Prime Bidder/Offeror
5. Conflict of Interest
6. Contractor Affidavit and Agreement (E-Verify User ID Number must be provided)

Attachment B Must be Notarized & Two (2) Pages Must be returned with your submittal - No Exceptions.

Business License Requirement: Bidder must be licensed in the Governmental entity for where they do the majority of their business. Your **company's business license number must** be provided on Page 1 of Attachment B. If your Governmental entity (State or Local) does not require a business license, your company will be required to obtain a Richmond County business license if awarded a contract. For further information contact the License and Inspection Department @ 706 312-5050.

Acknowledgement of Addenda: You Must acknowledge all Addenda. See Page 1 of Attachment B.

E-Verify * User Identification Number (Company I.D.) The recommended awarded vendor will be required to provide a copy of Homeland Security's Memorandum Of Understanding (MOU). **Contractors, Bids, RFPs, RFQs - Any** contractors performing the physical performance of services" for your city, including those that respond to bids or requests for bids, must submit an E-Verify affidavit. Your city cannot consider any contractors, even as part of a bidding or RFP process, unless they have given you the appropriate E-Verify contractor affidavits.

Contractors are defined as those who provide any "physical performance of services," which means any performance of labor or services for a public employer using a bidding process or by contract that costs over \$2,499.99 in value between December 1 and November 30 of any given year. Typically, eligible contracts may include: New construction or the demolition of structures/roads Routine operation, repair, and maintenance of existing structures. Any contracts for labor and service that exceed \$2,499.99. Contracts for the purchase of goods without any services provided are not subject to these E-Verify requirements.

The city, each contractor, and each subcontractor have different roles and responsibilities in the E-Verify process. The city collects E-Verify affidavits from the contractor. The contractor collects E-Verify affidavits from its subcontractors. The subcontractors collect E-Verify affidavits from its sub-subcontractors. Independent contractors (those with no employees) do not need to supply E-Verify information. Instead, they will provide a driver's license or state identification card from states on the "compliant" list created by the Georgia Attorney General. Those contractors and subcontractors that fill out the affidavits are responsible for the accuracy of the information. The city does not need to confirm that the E-Verify information is correct. The liability for incorrect information is on the contractor or subcontractor. NOTE: The authorization date can be found within the Memorandum of Understanding (MOU).

Affidavit Verifying Status for Augusta Benefit Application (S.A.V.E. Program) (Must Be Returned With Your Submittal)

The successful Bidder will submit the following forms to the Procurement Department no later than five (5) days after receiving the "Letter of Recommendation" (Vendor's letter will denote the date forms are to be received)

1. Georgia Security and Immigration Subcontractor Affidavit
2. Non-Collusion Affidavit of Sub-Contractor
3. **PLEASE NOTE GEORGIA LAW CHANGE: E-Verify and Public Contracts:** The Georgia E-Verify law requires contractors and all sub-contractors on Georgia public contract (contracts with a government agency) for the physical performance of services over \$2,499 in value to enroll in E-Verify, **regardless of the number of employees.** They may be exempt from this requirement if they have no employees and do not plan to hire employees for the purpose of completing any part of the public contract. Certain professions are also exempt. All requests for bids issued by a city must include the contractor affidavit as part of the requirement for their bid to be considered.

WARNING:

Please review "Notice to Bidder" regarding Augusta Georgia's Local Small Business Opportunity Program Bidder Requirements.

Vendors are cautioned that acquisition of bid documents through any source other than the office of the Procurement Department is not advisable. Acquisition of bid documents from unauthorized sources places the proposer at the risk of receiving incomplete or inaccurate information upon which to base his qualifications.

Bids are publicly opened. It is your responsibility to ensure that your company has met the Specifications and Licenses requirements prior to submitting a bid.



Attachment B

You Must Complete and Return the 2 pages of Attachment B with Your Submittal. Document Must Be Notarized.

Augusta, Georgia Augusta Procurement Department

ATTN: Procurement Director

535 Telfair Street, Suite 605

Augusta, Georgia 30901

Name of Bidder: _____

Street Address: _____

City, State, Zip Code: _____

Phone: _____ Fax: _____ Email: _____

Do You Have A Business License? Yes: _____ No: _____

Augusta, GA Business License # for your Company (Must Provide): _____

And/or Your State/Local Business License # for your Company (Must Provide): _____

Utility Contractors License # (Must Provide if applicable): _____ MUST BE LISTED ON FRONT OF ENVELOPE

General Contractor License # (Must Provide if applicable): _____

Additional Specialty License # (Must Provide if applicable): _____

NOTE: Company must be licensed in the Governmental entity for where they do the majority of their business. If your Governmental entity (State or Local) does not require a business license, please state above (Procurement will verify), your company will be required to obtain a Richmond County business license if awarded a BID. For further information regarding Augusta, GA license requirements, please contact the License and Inspection Department @ 706 312-5050.

List the State, City & County that issued your license: _____

Acknowledgement of Addenda: (#1) _____: (#2) _____: (#3) _____: (#4) _____: (#5) _____: (#6) _____: (#7) _____: (#8) _____:

NOTE: CHECK APPROPRIATE BOX (ES) - ADD ADDITIONAL NUMBERS AS APPLICABLE

Statement of Non-Discrimination

The undersigned understands that it is the policy of Augusta, Georgia to promote full and equal business opportunity for all persons doing business with Augusta, Georgia. The undersigned covenants that we have not discriminated against, on the basis of race, religion, gender, national origin or ethnicity, with regard to prime contracting, subcontracting or partnering opportunities.

The undersigned covenants and agrees to make good faith efforts to ensure maximum practicable participation of local small businesses on the bid or contract awarded by Augusta, Georgia. The undersigned further covenants that we have completed truthfully and fully the required forms regarding good faith efforts and local small business subcontractor/supplier utilization.

The undersigned further covenants and agrees not to engage in discriminatory conduct of any type against local small businesses, in conformity with Augusta, Georgia's Local Small Business Opportunity Program. Set forth below is the signature of an officer of the proposer/contracting entity with the authority to bind the entity.

The undersigned acknowledge and warrant that this Company has been made aware of understands and agrees to take affirmative action to provide such companies with the maximum practicable opportunities to do business with this Company;

That this promise of non-discrimination as made and set forth herein shall be continuing in nature and shall remain in full force and effect without interruption;

That the promises of non-discrimination as made and set forth herein shall be and are hereby deemed to be made as part of and incorporated by reference into any contract or portion thereof which this Company may hereafter obtain and;

That the failure of this Company to satisfactorily discharge any of the promises of nondiscrimination as made and set forth herein shall constitute a material breach of contract entitling Augusta, Georgia to declare the contract in default and to exercise any and all applicable rights remedies including but not limited to cancellation of the contract, termination of the contract, suspension and debarment from future contracting opportunities, and withholding and or forfeiture of compensation due and owing on a contract.

Non-Collusion of Prime Bidder

By submission of a bid, the vendor certifies, under penalty of perjury, that to the best of its knowledge and belief:

(a) The prices in the bid have been arrived at independently without collusion, consultation, communications, or agreement, for the purpose of restricting competition, as to any matter relating to such prices with any other vendor or with any competitor.

(b) Unless otherwise required by law, the prices which have been quoted in the bid have not been knowingly disclosed by the vendor prior to opening, directly or indirectly, to any other vendor or to any competitor.

(c) No attempt has been made, or will be made, by the vendor to induce any other person, partnership or corporation to submit or not to submit a bid for the purpose of restricting competition. Collusions and fraud in bid preparation shall be reported to the State of Georgia Attorney General and the United States Justice Department.

You Must Complete and Return the 2 pages of Attachment B with Your Submittal. Document Must Be Notarized.

Conflict of Interest

By submission of a bid, the responding firm certifies, under penalty of perjury, that to the best of its knowledge and belief:

- 1. No circumstances exist which cause a Conflict of Interest in performing the services required by this BID, and
- 2. That no employee of the County, nor any member thereof, nor any public agency or official affected by this BID, has any pecuniary interest in the business of the responding firm or his sub-consultant(s) has any interest that would conflict in any manner or degree with the performance related to this BID. By submission of a bid, the vendor certifies under penalty of perjury, that to the best of its knowledge and belief:
 - (a) The prices in the bid have been arrived at independently without collusion, consultation, communications, or agreement, for the purpose of restricting competition, as to any matter relating to such prices with any other vendor or with any competitor.
 - (b) Unless otherwise required by law, the prices which have been quoted in the bid have not knowingly been disclosed by the vendor prior to opening, directly or indirectly, to any other vendor or competitor.
 - (c) No attempt has been made, or will be made, by the vendor to induce any other person, partnership or cooperation to submit or not to submit a bid for the purpose of restricting competition. For any breach or violation of this provision, the County shall have the right to terminate any related contract or agreement without liability and at its discretion to deduct from the price, or otherwise recover, the full amount of such fee, commission, percentage, gift, payment or consideration.

Contractor Affidavit and Agreement: Contractor Affidavit under O.C.G.A. § 13-10-91(b) (I)

GEORGIA E-Verify and Public Contracts: The Georgia E-Verify law requires contractors and all sub-contractors on Georgia public contract (contracts with a government agency) for the physical performance of services **over \$2,499 in value to enroll in E-Verify, regardless of the number of employees.** They may be exempt from this requirement if they have no employees and do not plan to hire employees for the purpose of completing any part of the public contract. Certain professions are also exempt. All requests for bids issued by a city must include the **contractor affidavit** as part of the requirement for their bid to be considered.

The undersigned contractor ("Contractor") executes this Affidavit to comply with O.C.G.A § 13-10-91 related to any contract to which Contractor is a party that is subject to O.C.G.A. § 13-10-91 and hereby verifies its compliance with O.C.G.A. § 13-10-91, attesting as follows:

- a) The Contractor has registered with, is authorized to use and uses the federal work authorization program commonly known as E-Verify, or any subsequent replacement program;
- b) The Contractor will continue to use the federal work authorization program throughout the contract period, including any renewal or extension thereof;
- c) The Contractor will notify the public employer in the event the Contractor ceases to utilize the federal work authorization program during the contract period, including renewals or extensions thereof;
- d) The Contractor understands that ceasing to utilize the federal work authorization program constitutes a material breach of Contract;
- e) The Contractor will contract for the performance of services in satisfaction of such contract only with subcontractors who present an affidavit to the Contractor with the information required by O.C.G.A. § 13-10-91(a), (b), and (c);
- f) The Contractor acknowledges and agrees that this Affidavit shall be incorporated into any contract(s) subject to the provisions of O.C.G.A. § 13-10- 91 for the project listed below to which Contractor is a party after the date hereof without further action or consent by Contractor; and
- g) Contractor acknowledges its responsibility to submit copies of any affidavits, drivers' licenses, and identification cards required pursuant to O.C.G.A. § 13-10-91 to the public employer within five business days of receipt.

Georgia Law requires your company to have an E-Verify*User Identification Number (Company I.D.) on or after July 1, 2009.

For additional information or to enroll your company, visit the **State of Georgia** website:

<https://e-verify.uscis.gov/enroll/> and/or http://www.dol.state.ga.us/pdf/rules/300_10_1.pdf

Federal Work Authorization User Identification Number: E-VERIFY REQUIRED FOR ALL CONTRACTS OVER \$2,499.00

Date of Authorization

**** (E-Verify Number)** _____

Name of Contractor

Name of Project / Bid Number

AUGUSTA, GEORGIA – RICHMOND COUNTY CONSOLIDATED GOVERNMENT

Name of Public Employer

I hereby declare under penalty of perjury that the foregoing is true and correct.

Executed on _____, _____, 20_____ in _____ (City), _____ (State).

Signature of Authorized Officer or Agent

Printed Name and Title of Authorized Officer or Agent

SUBSCRIBED AND SWORN BEFORE ME ON THIS THE _____ DAY OF _____, 20_____

Notary Public

My Commission Expires:

NOTARY SEAL

The undersigned further agrees to submit a notarized copy of Attachment B and any required documentation noted as part of the Augusta, Georgia Board of Commissions specifications which govern this process. In addition, the undersigned agrees to submit all required forms for any subcontractor(s) as requested and or required. **I further understand that my submittal will be deemed non-compliant if any part of this process is violated.**

You Must Complete and Return the 2 pages of Attachment B with Your Submittal. Document Must Be Notarized.



You Must Complete and Return with Your Submittal. Document Must Be Notarized

Systematic Alien Verification for Entitlements (SAVE) Program

Affidavit Verifying Status for Augusta, Georgia Benefit Application By executing this affidavit under oath, as an applicant for an Augusta, Georgia Business License or Occupation Tax Certificate, Alcohol License, Taxi Permit, Contract or other public benefit as reference in O.C.G.A. Section 50-36-1, I am stating the following with respect to my bid for an Augusta, Georgia contract for

[Bid Project Number and Project Name]

[Print/Type: Name of natural person applying on behalf of individual, business, corporation, partnership, or other private entity]

[Print/Type: Name of business, corporation, partnership, or other private entity]

1.) I am a citizen of the United States.

OR

2.) I am a legal permanent resident 18 years of age or older.

OR

3.) I am an otherwise qualified alien (8 § USC 1641) or nonimmigrant under the Federal Immigration and Nationality Act (8 USC 1101 et seq.) 18 years of age or older and lawfully present in the United States.

In making the above representation under oath, I understand that any person who knowingly and willfully makes a false, fictitious, or fraudulent statement or representation in an affidavit shall be guilty of a violation of Code Section 16-10-20 of the Official Code of Georgia.

Signature of Applicant

Printed Name

* Alien Registration Number for Non-Citizens

SUBSCRIBED AND SWORN BEFORE ME ON THIS THE DAY OF , 20

Notary Public

My Commission Expires:

NOTARY SEAL

Note: THIS FORM MUST BE COMPLETED AND RETURNED WITH YOUR SUBMITTAL



**TRADE SECRET STATUS AFFIDAVIT
Augusta, Georgia**

All documents, data, letters and generated information received by Augusta, Georgia constitutes a "public record" and is subject to disclosure under the Georgia Open Records Act ("GORA"). O.C.G.A. § 50-18-70 *et seq.* However, pursuant to O.C.G.A. § 50-18-72(a)(34), "[an] entity submitting records containing trade secrets that wishes to keep such records confidential under this paragraph shall submit and attach to the records an affidavit affirmatively declaring that specific information in the records constitute trade secrets pursuant to Article 27 of Chapter 1 of Title 10 [O.C.G.A. § 10-1-760 *et seq.*]."

O.C.G.A. § 10-1-761(4) defines "Trade secret" as "...information, without regard to form, including, but not limited to, technical or nontechnical data, a formula, a pattern, a compilation, a program, a device, a method, a technique, a drawing, a process, financial data, financial plans, product plans, or a list of actual or potential customers or suppliers which is not commonly known by or available to the public and which information:

- A. Derives economic value, actual or potential, from not being generally known to, and not being readily ascertainable by proper means by, other persons who can obtain economic value from its disclosure or use; and
- B. Is the subject of efforts that are reasonable under the circumstances to maintain its secrecy."

Therefore, the records listed below and attached hereto, that were submitted with _____ response to Augusta, Georgia Request for Bid, Request for Quote, or Request for Qualified Contractor _____ are marked confidential pursuant to O.C.G.A. § 10-1-761(4):

- (List specific information that the supplier wishes to withhold and how that information constitutes a trade secret)
- Additional trade secret information requested to be withheld
- **Your company is requested to send a redacted copy of your submittal.**

Under penalty of perjury, acknowledging that O.C.G.A. §16-10-71 provides a penalty of a fine of up to \$1,000 and potential imprisonment of one to five years, I attest that the specific information in the records listed above constitutes trade secrets pursuant to O.C.G.A. § 10-1-761(4), and request that Augusta, Georgia not disclose this protected information under the Georgia Open Records Act ("GORA").

Signature:

[Signatory Name in Print]

[Signatory's Title] [Company Name]

[Signatory's Title]

Date: _____

**SUBSCRIBED AND SWORN BEFORE
ME ON THIS _____ DAY OF
_____, 202_.**

NOTARY PUBLIC

My Commission Expires: _____

Return form only if applicable. If form is not returned with your submittal, it will be deemed there are no trade secrets in your package submittal.



EXCEPTION SHEET

If the commodity (ies) and/or services proposed in the response to this bid is in anyway different from that contained in this bid, the bidder is responsible to clearly identify by specification section number, all such differences in the space provided below. Otherwise, it will be assumed that bidder(s) offer is in total compliance with all aspects of the bid.

Below are the exceptions to the stated specifications:

Signature

Date

Company

Title

Return with submittal if the commodity and/or services proposed in the response to this bid are in any way different from that contained in the specifications.



VIN: _____
 Expiration Date: _____
 (For Internal Use Only)

Local Vendor Registration Form

- (a) Augusta, Georgia encourages the use of local suppliers of goods, services and construction products whenever possible. Augusta, Georgia also vigorously supports the advantages of an open competitive marketplace. Nothing in this Section shall be interpreted to mean that Augusta, Georgia Administrator or Procurement Director are restricted in any way from seeking formal bids or bids from outside the Augusta market area.
- (b) The Local Vendor Preference policy shall only be applied to projects of one-hundred thousand dollars (\$100,000) or less and only when the lowest local qualified bidder is within 10% or \$10,000, whichever is less of the lowest non-local bidders. The lowest local qualified bidder will be allowed to match the bid of the lowest non-local bidder and, if matched, the lowest local qualified bidder will be awarded the contract.

Please Check **Criteria** (Subparagraph "e" of the AUGUSTA, GA. CODE)

Yes ___ No ___

1. Has had a fixed office or distribution point in and having a street address within the geographic limits of Richmond County, Georgia for at least six (6) months immediately prior to the issuance of the request for bids or quotes by Augusta; and

Yes ___ No ___

2. Holds any business license required by the AUGUSTA, GA. CODE; and

Yes ___ No ___

3. Employs at least one full-time employee, or two part-time employees whose primary residence is within the geographic limits of Richmond County, Georgia or if the business has no employees, the business shall be at least fifty percent (50%) owned by one or more persons whose primary residence is within the geographic limits of Richmond County, Georgia.

- (c) Nothing in this section shall be interpreted to mean that the Augusta, Georgia Administrator or Commission may decline to follow the provisions of O.C.G.A. §§ 36-91-1 through 36-91-95, Public Works Contracts. O.C.G.A. § 36-91-22 requires that all Augusta, Georgia public works contracts of one-hundred thousand dollars (\$100,000) or more, as defined therein, be publicly advertised before letting out the contract to the lowest bidder. Further, nothing in this section shall be interpreted to mean Augusta, Georgia Administrator or Board of Commissioners may decline to follow the provisions of the AUGUSTA, GA. CODE requiring public advertising before letting certain contracts.

Term. The certification as a local bidder shall expire two (2) years from the date of the approval of the application. Following the expiration date, a business is no longer a local bidder. An eligible bidder must submit a new application for certification as a local bidder to the Procurement Director and establish that it continues to meet the requirements contained in subparagraph (e) (See Criteria above) of this section in order to receive a bid preference on eligible local projects. Please review the Augusta Code in its entirety at www.augustaga.gov.

Company Name _____ Address: _____ City: _____ State: _____ Zip: _____ Phone # _____ Fax #: _____ Owner's Name: _____ Owner's Signature: _____	Sworn to and subscribed before me this _____ day of _____, 20____ Notary Signature _____ Notary Public: _____ (Print Name) County: _____ State: _____ Commission Expires: _____ <p style="text-align: center;">NOTARY SEAL</p>
--	--

Minority and Women Owned Business Enterprise Program Ordinance Requirements

Notice To All Bidders (PLEASE READ CAREFULLY)

Shall apply to ALL Bids regardless of the dollar amount

In accordance with the Commission Action on 7/25/24 and the adoption of Ordinance No. 7945 Chapter 10C of the AUGUSTA, GA, CODE, Contractors agree to collect and maintain all records necessary to Augusta, Georgia to evaluate the effectiveness of its Minority and Women Owned Business Enterprise Program and to make such records available to Augusta, Georgia upon request. The requirements of the Minority and Women Owned Business Enterprise Program can be found at www.augustaga.gov. In accordance with AUGUSTA, GA. CODE, Contractors shall report to Augusta, Georgia the total dollars paid to each subcontractor, vendor, or other business on each contract, and shall provide such payment affidavits, regarding payment to subcontractors, if any as required by Augusta, Georgia. Such utilization reports shall be in the format specified by the Director of Compliance and shall be submitted at such times as required by Augusta, Georgia. Required forms can be found at www.augustaga.gov. If you need assistance completing a form or filing information, please contact the M/WBE Program office at (706) 821-2406. Failure to provide such reports within the time period specified by Augusta, Georgia shall entitle Augusta, Georgia to exercise any of the remedies set forth, including, but not limited to, withholding payment from the Contractor and/or collecting liquidated damages.

SHALL APPLY TO PROJECTS IN EXCESS OF \$300,000
Minority and Women Owned Business Enterprise Program (Continued)

Sec. 1-10-138. Race and Gender-Conscious Efforts Contract-by-Contract Subcontractor Goals The City, through the Goal Setting Committee (GSC), will set specific, separate percentage-based MBE and WBE subcontracting goals on a contract-by contract basis for Prime contracts in Construction, Architecture & Engineering, Professional Services, and Other Services valued in excess of \$300,000. The City shall establish such goals based upon the type of contract, the type of subcontracting work that will be required, and the availability of M/WBE firms to perform the work for that specific contract.

The GSC shall not establish subcontracting goals on contracts where (a) there are no subcontracting opportunities identified for the contract; or (b) there are not at least three (3) MBE and/or WBE firms that are available and capable to perform a CUF for the overall subcontracting opportunities on the contract.

Good Faith Efforts (GFE) Requirements and Guidance

1. Achievement of subcontracting goals or documentation of Good Faith Efforts applies to every Contract for which such goals are established. **The Bidder shall submit a compliance plan detailing its achievement of the goals or its Good Faith Efforts to meet the goals. The compliance plan shall be due at the time set out in the solicitation documents.**

2. When a Bidder cannot achieve the goals, its compliance plan shall document its GFE to achieve the goals. The Director of Compliance will determine whether the Bidder has made such GFE.

Bid Documents

All bid documents shall require bidders or Bidders to submit with their bid the following written documents, statements, or forms, which shall be made available by the Procurement Department.

- Proposed Letter of Intent MBE/WBE.
- Proposed MBE/WBE Utilization Plan.
- Documentation of Good Faith Efforts Form (*in the event the bidder will not meet the MBE and WBE goals*).

Failure to submit the above documentation shall result in the bid being declared non-responsive.

Sec. 1-10-154. Exceptions

In accordance with § 1-10-8, on federally funded projects or contracts, the M/WBE Program shall only be utilized when authorized by the applicable federal (and/or Georgia) laws, regulations, and conditions relating to that project or contract. To the extent that there are any conflicts between any such laws, regulations, or conditions and the provisions of the M/WBE Program, the federal (and/or Georgia) guidance shall control.

NOTE: All forms should be submitted in a separate, sealed envelope, labeled M/WBE Forms, Company's Name & Bud number

For questions and or additional information, please contact:

Minority-Owned and Women-Owned Business Enterprise Program
535 Telfair Street, Suite 530
Augusta, Georgia 30901
(706) 821-2406
mwbe@augustaga.gov

Website: <https://www.augustaga.gov/83/Disadvantaged-Business-Enterprise>

REV. 9/6/24

INSTRUCTIONS TO SUBMIT

Augusta is seeking to secure a vendor to provide **Cell Light Installation for Charles B. Webster Detention Center (CBWDC)** for the Augusta, Georgia Sheriff's Office. Your submittal should respond to, and be based on, the information included in this Invitation to Bid.

Bids will be received by the Augusta Commission, (hereinafter called the "Owner"), at the office of the Procurement Director, 535 Telfair Street, Room 605, Augusta, GA until Friday, October 31, 2025 @ 11:00 a.m., and then, at said office, publicly opened and read aloud. Each bid must be submitted in a sealed envelope and must be plainly marked on the outside as a bid for **"Bid Item 25-244 Cell Light Installation for Charles B. Webster Detention Center (CBWDC)"** and the envelope should bear on the outside the name of the bidder, his address and his license number, if applicable.

Opening will be held via TEAMS: Meeting ID: 222 976 220 355; Passcode: 25242

If the bid is forwarded by mail, or other second party delivery service, the sealed envelope containing the bid must be enclosed in another envelope addressed to:

Andy Penick
Procurement Director
535 Telfair Street, Room 605
Augusta, Georgia 30901

Bid Packages may be obtained at the Augusta Procurement Department, at the address listed above. The Bid Package contains provisions required for the specifications. All firms responding are cautioned to read this information carefully for understanding and request clarification from Augusta on any questions pertaining to this request.

For an optional site visit, please contact Chester Huffman in advance at (706) 821-1442 or via email at cvhuffman@augustaga.gov.

All questions must be submitted in writing by email to procbidandcontract@augustaga.gov to the office of the Procurement Department by Friday, October 17, 2025 @ 5:00 P.M. No bid will be accepted by email; all bids must be received by mail or hand delivered.

Interested firms are cautioned that acquisition of Bid Documents through any source other than the office of the Procurement Department is not advisable. Acquisitions of said documents from unauthorized sources place the bidder at the risk of receiving incomplete or inaccurate information upon which to base their proposal.

Correspondence must be submitted via mail or email as follows:

Augusta Procurement Department
Andy Penick, Procurement Director
535 Telfair Street, Room 605
Augusta, Georgia 30901
Email: procbidandcontract@augustaga.gov

To ensure timely deliveries, all submittals must be received during our normal office hours from 8:30 a.m. to 5:00 p.m., Monday through Friday. No deliveries will be accepted prior to 8:30 a.m. or after 5:00 p.m., as the building is closed to the public and delivery services outside of these hours.

No bid will be accepted by email; all bids must be received by mail or hand delivered. All bids must be made on the required Bid Form. All blank spaces for bid prices must be filled in with ink or typewritten, and the form

must be fully completed and executed when submitted. Failure to provide all of the requested information may cause the bid to be rejected as non-responsive. An official authorized to bind the firm to the terms and provisions of the bid must sign the bid form.

All interested firms are required to meet Federal, State and Local laws and regulations.

The Owner may waive any informalities or minor defects or reject any and all bids. Any bid may be withdrawn prior to the above scheduled time for the opening of bids or authorized postponement thereof. Any bid received after the time and date specified shall not be considered.

No bids may be withdrawn for a period of ninety **(90)** days after bids have been opened, pending the execution of contract with the successful bidder. Should there be reasons why the Contract cannot be awarded within the specified period, the time may be extended by mutual agreement between the Owner and the bidder.

After bids have been submitted, the bidder shall not assert that there was a misunderstanding concerning the nature of the work to be done.

The party to whom the contract is awarded will be issued a Notice of Award. Should there be reasons why the Notice of Award cannot be issued, the time may be extended by mutual agreement between the Owner and the Contractor.

The Owner may make such investigations as he deems necessary to determine the ability of the bidder to perform the work and the bidder shall furnish to the Owner all such information and data for this purpose as the Owner may request. The Owner reserves the right to reject any bid if the evidence submitted by or investigation of such bidder fails to satisfy the Owner that such bidder is properly qualified to carry out the obligations of the Agreement and complete the work contemplated therein.

A conditional or qualified bid will not be accepted. Award will be made as a whole to one bidder.

The Owner reserves the right to consider proposals or modifications thereof received at any time before the award is made if such action is in the interest of the Owner.

Each bidder is responsible for reading and being thoroughly familiar with the specifications. The failure or omission of any bidder to do any of the foregoing shall in no way relieve any bidder from any obligation in respect to his bid.

The Owner will not be liable for any costs incurred by any firm prior to receiving the Notice of Award.

INTRODUCTION:

The Augusta Richmond County Sheriff’s Office (RCSO) is seeking bids for installation of 377 Cell Light Fixtures for the Charles B. Webster Detention Center (CBWDC) located at:

**Charles B. Webster Detention Center (CBWDC)
1941 Phinizy Rd.
Augusta, GA 30906**

BACKGROUND:

Originally constructed in 1997, the CBWDC cells and cell blocks were constructed with ceiling lights of a “maximum security” grade. Today, the Sheriff’s Office is facing a problem with inmates destroying these ceiling lights and repurposing the metal for weapons. There are many cells that have had all light fixtures removed by inmates as well as numerous incidents of assault resulting in serious injury.

SCOPE OF SERVICES:

The Richmond County Sheriff’s Office (RCSO) – Charles B. Webster Detention Center (CBWDC) located at 1941 Phinizy Road is requesting bids from vendors for the removal of 606 existing security light fixtures within 351 cells and install 377 Shat-r-shield VR Pro light fixtures and VR Pro Surface Boxes within 351 cells.



SPECIFICATIONS:

The specifications listed below are the minimum requirements:

- Remove 2 existing light fixtures (some cells have more) from each cell – a total of 606 fixtures. The vendor is responsible for removal of the fixtures from the property.
- Install 1 (or 2) new security light fixtures in each cell – a total of 377 fixtures.
- The unused junction box in each cell to be sealed with a 6" x 6" blank cover.
- Pick-proof caulk to be used around blank cover and new security light fixtures.
- New light fixtures to be installed using drive-pin anchors.
- Pick-proof caulk and cover plates to be provided by vendor
- Light fixtures, Surface Boxes and drive-pin anchors to be provided by CBWDC
- Requested installation quantity is 377, however the actual installation quantity may be more or less than the amount listed.

The light fixtures and mounting boxes or approved equivalent are described below. These items will be provided by Augusta:

- Shat-r-shield Ironclad VR Pro, 42 w, VR Pro, 5000k, Ceiling Mount, Count Light, 120-277V, 304 Stainless, Urethane, Tamperproof Bolts & Inserts (**See Exhibit A**)
- VR Pro Surface Box (**See Exhibit B**)

MINIMUM REQUIREMENTS:

The following outlines the minimum requirements of the specifications. Contractor proposed service is to include but not limited to the following:

- The successful contractor shall be required to provide at minimum the services outlined in this scope.
- The successful contractor shall conform to all applicable federal, state and local codes. Included, but not limited to, the **National Electrical Code (NFPA 70-2020)**.
- The successful contractor shall request and provide all required permits.
- The successful contractor shall be required to furnish all equipment, machinery, transportation, and other implements necessary to execute this bid.
- The successful contractor shall be required to furnish all materials, safety measures and property protection needed to complete the scope of work outlined and protect the facility from damage.
- The successful contractor shall remove all debris from the areas and properly dispose of this material.
- A background check will be required for any person that will be on site. The cost of the background check will be covered by the Sheriff's Office.

The requested bid is for the removal of existing lights and installation of light and surface box. Lights and surface box to be provided by Augusta.

INDEMNIFICATION AND INSURANCE:

The offerer shall carry general liability insurance coverage in the amount of One Million Dollars (\$1,000,000). This policy shall cover the firm and all of its employees and agents, and shall indemnify and hold harmless Augusta, Georgia and their representatives and employees, from any claim, demands, actions, and cause for actions arising from any act or non-act or the commission or omission of any act while under the terms of the contract.

POINT OF CONTACT:

All questions should be directed to Andy Penick, Procurement Director, and must be in writing by email to procbidandcontract@augustaga.gov. The last day to submit questions is Friday, October 17, 2025, 5:00 P.M.

SPECIAL CONDITIONS:

The successful bidder may not subcontract any part of the work covered by this contract without prior written approval of the Sheriff's Office.

BID FORM

PRICING: _____

The vendor proposes to undertake the referenced project as shown in this Invitation for Bids and all exhibits at the following quoted price to include but not limited to labor, materials, supplies, equipment, clean-up (debris removal & disposal).

Installation Unit Cost Per Each Light Installation: \$ _____

Total Installation (Individual unit cost X 377) \$ _____
(Total units to be installed are estimated at 377 units)

SUBMITTED BY:

COMPANY: _____

NAME: _____ SIGNATURE: _____

ADDRESS: _____

CITY/STATE: _____

TELEPHONE: _____

EMAIL: _____

By signing this document, the bidder is stating that he is, or she is not an employee of Augusta, Georgia.

AUGUSTA RESERVES THE RIGHT TO REJECT ANY AND ALL BIDS

ACKNOWLEDGEMENT OF TERMS AND CONDITIONS:

Bidder shall acknowledge agreement with each statement by placing a check mark within the parenthesis to left.

- 1. All materials and or services furnished will be subject to the approval of the Commission, Augusta Administrator, Procurement Director, and Sheriff's Office.
- 2. **All questions should be directed to Andy Penick, Procurement Director, and must be in writing by email to procbidandcontract@augustaga.gov. The last day to submit questions is Friday, October 17, 2025 @ 5:00 p.m.**
- 3. Prices must be guaranteed for a minimum of ninety (90) days unless noted otherwise.
- 4. Bidder is not an employee of Augusta.
- 5. Warranties are to be as specified. All warranties, expressed or implied, must be submitted in writing and will become a part of the vendor's formal offering.
- 6. Proposer has reviewed the terms and conditions of the contract.

OFFEROR MUST RETURN THIS COMPLETED FORM WITH THE BID SUBMITTAL

- 7. Warranty is to be as specified.
- 8. Proposer has reviewed the terms and conditions of this agreement.
- 9. Bidders are to review the facility and provide an all-inclusive bid for the scope of work described, including alternates and state the time duration to do the work once a purchase order is issued.
- 10. The entire project must be planned, coordinated, and completed in a manner that minimizes disruption to the normal operations of the facility. All work will be coordinated, scheduled, reviewed, and approved through the Sheriff's Office.
- 11. All equipment, fasteners, and materials of associated work is to meet all applicable codes.
- 12. Contractor will be responsible for acquiring all required permits, licenses, and governmental authorizations (if necessary) to perform all required work and duties. Contractor will maintain these requirements for the life of the agreement.
- 13. Delivery, storage, handling, and security of all materials and equipment shall be the responsibility of the contractor and at a minimum shall be conducted in accordance with the manufacturer's recommendations. Augusta, Georgia will not accept any billings for stored materials, unless the equipment and materials are stored in a bonded warehouse at the cost to the contractor.
- 14. Clean-up work areas on a daily basis, remove all associated debris from the site and dispose of lawfully, and adhere to all laws, rules, and codes.
- 15. All applicable safety regulations will be followed by the contractor and subcontractors they employ during the entire construction process.
- 16. It is the contractor's sole responsibility for any time lost due to work being ceased due to failure to comply with any jurisdictional authority and any time lost due to such failure to comply will not be grounds for approving a contract extension.
- 17. Contractor shall be responsible for overseeing the work of all workers. Augusta may require the Contractor not to assign any worker Augusta deems incompetent, careless, insubordinate, or otherwise objectionable to work on Augusta jobs. All employees and sub-contractors must be qualified to legally work within the United States.
- 18. Any Contract resulting from this proposal shall not be subcontracted, assigned, or otherwise transferred to any other Contractor, in whole or in part, without prior written approval by the Owner. If subcontractors are to be utilized, then they must be listed in the proposal with all their backup information including but not limited to: a copy of the company's insurance, a copy of the company's contractor's license, provide a brief overview of the company's experience, qualifications and expected work they will perform, and a list of five (5) client references.

I hereby certify that the responses to the above representations, certifications, and other statements are accurate and complete. I agree to abide by all conditions of this Invitation to Bid and certify that I am authorized to sign for the Offeror.

Signature: _____

Date: _____

Name (Printed): _____

Title: _____

OFFEROR MUST RETURN THIS COMPLETED FORM WITH THE BID SUBMITTAL

Exhibit A

Specifications Ironclad VR Pro Vandal-Resistant Correctional Cell Light



Project		Date	
Type		Notes	

VR Pro™ Vandal-Resistant LED Correctional Cell Light

The Ironclad® VR Pro Vandal-Resistant correctional cell and behavioral room fixture uses an LED high efficiency light engine with a light that simulates daylight. The incorporated count light LED module gives off a soothing warm light that can be turned on and off as needed.

Construction

- One piece Mounting Ring- .500" thick 304 Stainless Steel
- Lens- .400" thick cast, diffused translucent, Highly Engineered Polyurethane. Shore hardness D80+, tensile strength 5,400 psi, impact strength 55 in. lbs./ in.
- Mounting- .125" aluminum heat sink to maintain thermal management
- Installation- Anchored flush onto ceiling with (8) recessed tamper-proof 1/4" concrete drive anchors or (8) 1/4" tamper-proof stainless steel bolts
- Wiring- Hard wired direct to AC current; eliminating failure points via driver
- Features- No accessible parts, No rusting or peeling paint, Count Light

Specifications

- Extreme Durability- hammer & knife tested
- 80 CRI
- No areas to hide or conceal contraband.
- Weight: 7.9 lbs.
- Dimensions: 12.25" diameter x 1.9" tall



Watts	35W or 42W
Voltage	120 or 277V
Lumens	3,600
Color Temperatures	5000K, 4000K, 3500K or 2700K; Count Light 2700K
LED Life	L70>75,000 Hours; Projected>100,000 Hours
Footcandles	35 ftc at the desk level; 22 ftc at the floor
Warranty	5 year limited warranty



Manufactured in America with globally and domestically sourced components

Ordering Guide

Wattage	Fixture	CCT	Mount	Count Light	Voltage	Ring Material	Lens	Access.	Access.	Access.	Rev
	VR									00	02
042 = 42W	VR = Vandal Resistant	50 = 5000K	CL = Ceiling	Y = Yes	VH = 120-277V	SS = 304 Stainless	UR = Urethane	00 = None	00 = None	00 = None	
		40 = 4000K	WL = Wall			TB = Tamper-proof Bolts & Inserts					
35 = 3500K		FT = Flat Top	N = No	P2 = Powder Coat, SS, White		PC = Polycarbonate	JB = Surface Box Kit		SA = Spike Anchors		
27 = 2700K		FW = Flat Wall		P5 = Powder Coat, SS, Brown					MS = Metal Ceiling Screws		

Exhibit B

Surface Box Specifications



ACCESSORY Selection Guide

Correctional Installation Anchor Types, Surface Boxes & Mounting Components

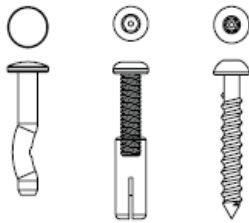

Anchor Selection

- 1.5" long, Round Head, Spike Anchor
- Removable, Tamper-proof Bolt For concrete using Torx T27
- Removable, Tamper-proof Screw For cinder blocks using Torx T27



- Hammer Drill Install Tool
- Spike Anchor Extraction Tool Designed by Shat-R-Shield for removal of round spike anchors

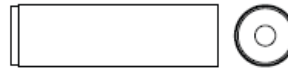

Surface Box Specs	
Material	14 Gauge Steel
Coating	Powder Coated with Polyester TGIC

Surface Box Accessory

Enclosure housing for electrical connections

Surface boxes protect the electrical connections from damage, as well as any self harm and accidental shocks. Sometimes these boxes can cover existing connections and any structural damage to ceilings, walls, etc.

Surface Box Dimensions

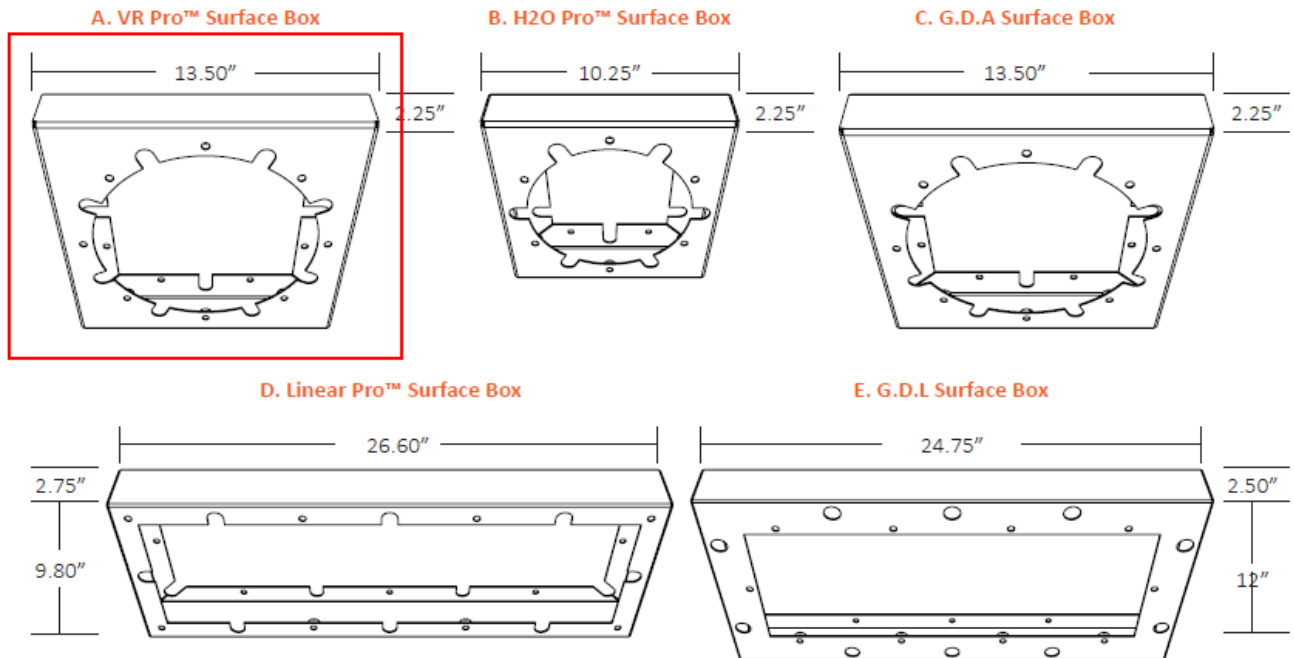

F. VR Pro™ Corner Box

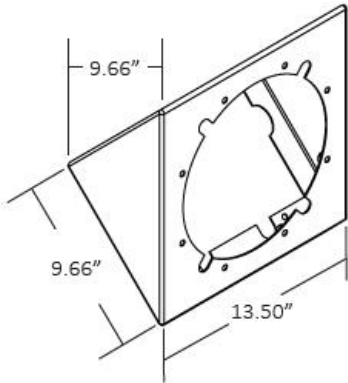

G. H2O Pro™ Corner Box

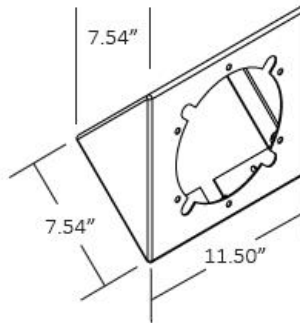

H. H2O Pro™ Down Light Box

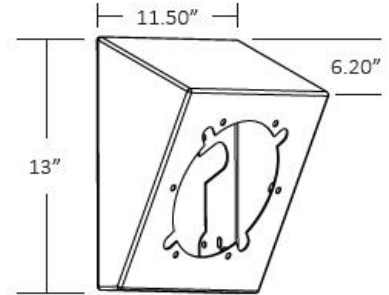

I. Linear Pro™ Corner Box

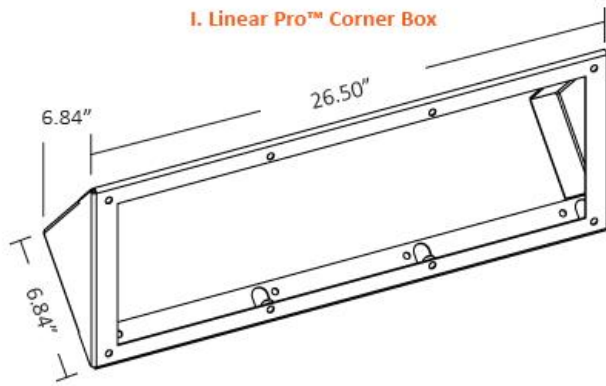

J. G.D.I Corner Box

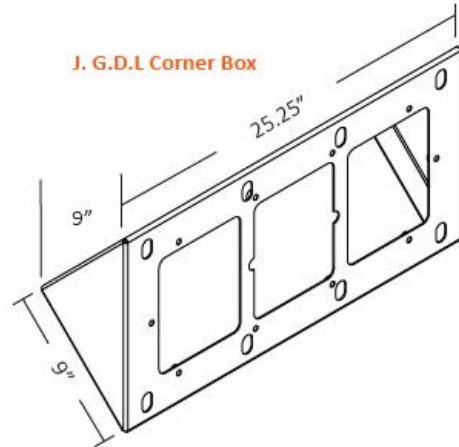

Surface Box Renderings



Fig. A



Fig. B



Fig. C



Fig. D



Fig. E



Fig. F



Fig. G



Fig. H



Fig. I



Fig. J

Local Small Business Program **Preference**

The Local Small Business Program provides for Local Small Business Program Preference on all applicable Augusta, Georgia procurements between \$101,000 and \$300,000 in value.

The Local Small Business Program Preferences for this procurement is:

Waived

There must be a minimum of three (3) certified firms in the Local Small Business Program that can provide the service or product, as specified by the user department, for the LSBP Preference to be considered. As a result of not meeting the minimum service/product requirement, the LSBP Preference is waived for this solicitation.

NO RESPONSE LETTER

Please submit Response by due date

Bid Item #25-244	Cell Light Installation for CBWDC	Due: Friday, October 31, 2025 @ 11:00 a.m.
-------------------------	--	---

To: **Augusta, Georgia - Procurement Department**

This is to certify that _____, will not be submitting a response to the above referenced solicitation document prepared by Augusta Procurement Department.

Reason(s) for No Submission:

Unavailability of required resources

Prior commitments

Inadequate anticipated funding Level

Project Duration

Potential conflict of interest

Duplication of ongoing effort

Other (please explain)

Authorized Representative:

Name: _____

Title: _____

Signature: _____

Date: ____/____/20____